

RECOMMENDED PCB LAYOUT (TOP VIEW)

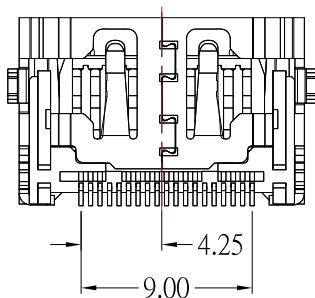
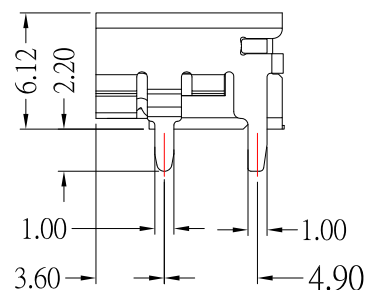
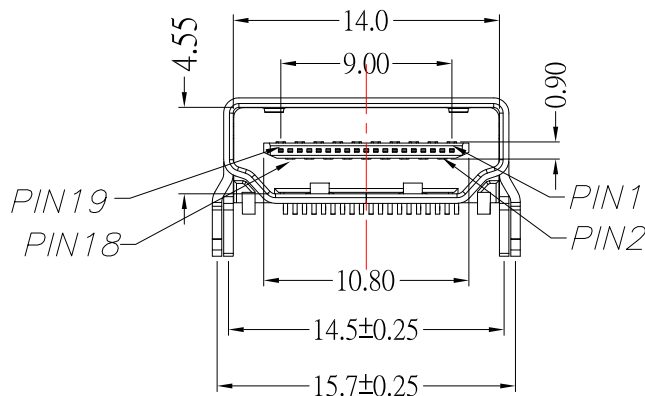

NOTE:

1.MATERIAL:

- 1.1 HOUSING: LCP,Black
- 1.2 CONTACT: BRASS
- 1.3 SHELL: BRASS

2.PLATING :

- 2.1 CONTACT: PLATED GOLD IN MATING AREA ;
TIN PLATED ON SOLDER BALLS ;
NICKEL UNDER PLATED OVERALL
- 2.2 SHELL: NICKEL UNDER PLATED SURFACE LAYER

3.ELECTRICAL:

- 3.1 RATING CURRENT: 0.5A
- 3.2 RATING VOLTAGE: 40V DC
- 3.3 CONTACT RESISTANCE: 30 mΩ Max
- 3.4 INSULATION RESISTANCE: 1000MΩ Min
- 3.5 WITHSTANDING VOLTAGE: 500V DC / minute
- 3.6 OPERATING TEMPERATURE: -25°C ~85°C

東莞市高迪電子有限公司
DONG GUAN GAO DI ELECTRONICS CO., LTD

TOLERANCE UNLESS OTHERWISE STATED :
Up to 5 ±0.2
Above 5 ~ 15 ±0.3
Above 15 ~ 30 ±0.4
Above 30 ~ 50 ±0.5
Angle ±0.3

3RD. ANGEL'S



UNITS MM

DRAWN BY:	DATE	MAT'L	TITLE	CONNECTOR
Jack Lu	07/05/22			
CHECKED BY:	DATE	FINISH	MODLE	HDMI A/F 短體無耳無柱 SMT
Jacky Chen	07/05/22			
APPROVED BY:	DATE	SCALE	DWG NO.	HDMI-19P-SND5-S277
Tony Kao	07/05/22	1 : 1		
		SHEET NO.	PART NO.	HDMI-19P-SND5-S277
		1 of 1		

3	新增OPERATING TEMPERATURE	Jack	070522
2	更新圖面	Jack	031920
1	更新料號	Jack	021115
ITEM NO.	DESCRIPTION	DRAWN	DATE